

MAD DOG



700R4/2004R TV Cable Adjustment Instructions

Important after you install your new Outlaw® 700R4/2004R transmission. You must properly adjust the throttle Valve (TV) or **DAMAGE WILL OCCUR** to the transmission, voiding the warranty.

If you are unsure about the proper adjustment needed, call Mad Dog Transmissions at 770-781-0949 for technical support.

Step 1 Obtain a cable that is designed for use with the 700R4/2004R transmission. Mad Dog recommends our universal TV Cable that is designed to work correctly in any 700R4/2004R application.

Step 2 With the carburetor/throttle body end of the TV Cable disconnected, pull the link out of the transmission and fit the cable end to the link as shown in **Figure 1**. Push the TV Cable sheath into the seal in the transmission and tighten the 10mm retaining bolt. (If your vehicle has a factory installed bracket for the TV Cable then skip to Step 4.)

Step 3 Install the bracket for your carburetor. This will allow the TV Cable to mount to the carburetor/throttle body. If you are using a Chevrolet TBI/TPI induction system, then correct brackets can be obtained from a salvage yard or a local car dealership.

Figure 2 demonstrates the correct geometry for the TV Cable mounting position. Use the following procedure to determine if your ADJUSTER MOUNTING POINT is correct.

a. Push in the Adjust Tab and retract the Slider in the direction shown in **Figure 3**.

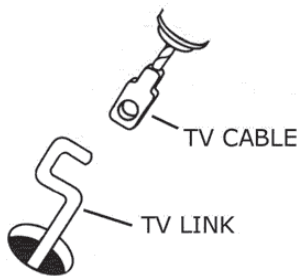

b. Without allowing the Slider to move, pull the cable until it stops and measure from the mounting bracket to the cable end. Add 3/16" to this measurement and that will determine the ADJUSTER MOUNTING POINT distance at full throttle (WOT).

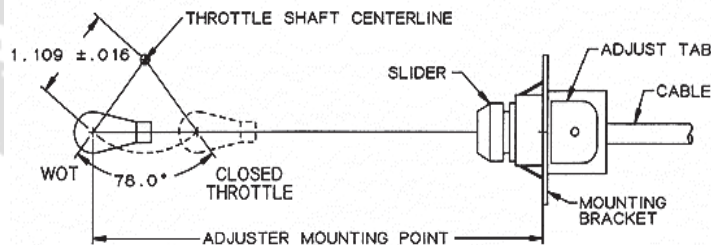

c. Also note in Figure 2 that the distance from the throttle shaft to the cable end is referenced. This distance must be between 1 7/64" and 1 1/8"! The cable end mounting point should follow a 78° arc between closed throttle and WOT in order to achieve the proper amount of pull on the cable.

Step 4 Adjustment of the TV Cable on a gasoline engine. (For a diesel application go to Step 5.)

a. Adjustments are made with the engine off. Locate the Adjust Tab on the cable housing. Press in the tab and push the slider as shown in **Figure 3**.

b. Release the tab and rotate the throttle lever to WOT and the cable will self adjust itself as evidenced by a few audible clicks. Release the throttle lever and check the cable for any signs of binding or sticking.

c. Road test the vehicle. Under moderate acceleration your shift points should be close to the following:

1-2.....15-20 MPH

2-3.....25-30 MPH

3-4.....40-45 MPH

If the cable is adjusted too loosely your transmission will exhibit soft, stacked shifts (not spread out). DO NOT CONTINUE

3600 North Parkway, Suite 105 • Cumming, GA 30040

Tel: 770-781-0949 • Fax: 770-781-0969

www.madogtransmissions.biz

DRIVING VEHICLE IF THIS HAPPENS! Immediately readjust cable. If you continue to have problems, please contact Outlaw's tech department for assistance.

Step 5 Adjustments of the TV Cable on a diesel engine.

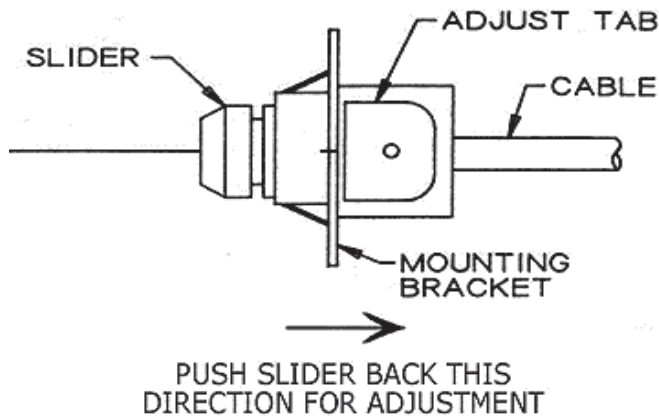

- Adjustments are made with the engine off. If equipped with cruise control, remove the control rod.
- Disconnect the TV Cable end from the throttle lever.
- Loosen the locknut on the pump rod and shorten several turns.
- Turn throttle lever to WOT and tighten the pump rod locknut.
- Lengthen pump rod until injection pump lever contacts the full throttle stop.
- Release the throttle lever and tighten the pump rod locknut.
- Remove pump rod from the throttle lever.

- Reconnect the TV Cable end to the throttle lever.
- Press in the Adjust Tab and move Slider as shown in Figure 3.
- Release the tab and rotate the throttle lever to WOT and the cable will self adjust itself as evidenced by a few audible clicks. Release the throttle lever and check the cable for any signs of binding or sticking.
- Reconnect the pump rod and cruise control throttle rod, if equipped.
- If equipped with cruise control, adjust servo throttle rod to minimum slack.
- Road test the vehicle. Under moderate acceleration your shift points should be close to the following:

1-2.....	15-20 MPH
2-3.....	25-30 MPH
3-4.....	40-45 MPH
- If the cable is adjusted too loosely your transmission will exhibit soft, stacked shifts (not spread out).

DO NOT CONTINUE DRIVING VEHICLE IF THIS HAPPENS!

Immediately readjust cable. If you continue to have problems, please contact Mad Dog's tech department for assistance at 770-781-0949.

3600 North Parkway, Suite 105 • Cumming, GA 30040
Tel: 770-781-0949 • Fax: 770-781-0969

www.maddogtransmissions.biz